

**SKINDICHT® SVFK-M**

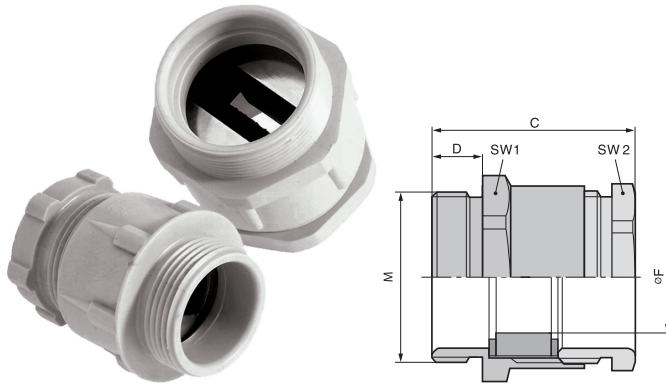

SKINDICHT® SVFK-M

**Benefits**

- Economic type
- Lateral sealing lips fit automatically around various cable dimensions
- Cable-specific seal dimensions are no longer necessary
- Dimensional adaptability
- Large clear opening allows clamping of up to two flat cables

**Application range**

- For inserting of flat cables.
- Conveyor systems
- Pumps
- Elevators
- Switch cabinet building

**Approvals (Norm references)**



**Design**

- Metric connection thread acc. to EN 50262

**Note**

- Counter nut to be used SKINTOP® GMP-GL-M
- For suitable flat cables, see ÖLFLEX® LIFT F for indoor applications or ÖLFLEX® CRANE F for outdoor applications

**Technical data**

- Caution**  
Installation dimensions see Appendix T21
- Material**  
Body: Polyamide  
Special sealing insert: CR
- Range of temperature**  
-30°C up to +80°C

Part number	Part designation / size	Flat cable width min./max.	Min./ max. cable thickness in mm	SW1 / SW2 mm	Overall length C mm	Thread length D mm	Pieces / PU
<b>SKINDICHT® SVFK-M</b>							
52107900	SVFK-M 25 x 1,5	- / 15.0	-- 5.0	23 / 27	41.0	11.0	25
52107901	SVFK-M 32 x 1,5	10.0 / 21.0	3.0 - 8.0	30 / 36	39.0	10.0	25
52107902	SVFK-M 40 x 1,5	16.0 / 28.0	4.0 - 11.5	40 / 42	44.0	11.0	25
52107903	SVFK-M 50 x 1,5	26.0 / 35.0	4.0 - 11.5	50 / 53	50.5	11.0	5
52107904	SVFK-M 50 x 1,5	30.0 / 40.0	5.0 - 15.0	55 / 60	53.5	11.0	5
52107905	SVFK-M 63 x 1,5	36.0 / 45.0	5.0 - 15.0	60 / 65	54.5	11.0	5